



ASSEMBLY & INSTALLATION



Cortesia:
PP5VX (Bone)
GG53qs

XM240

40 Meter 2 Element Yagi

... E A PARTIR DA **PÁGINA 13 (TREZE)** EXISTEM MAIS INFORMAÇÕES !



CUSHCRAFT
COMMUNICATIONS ANTENNAS

951477 (8/98)

XM240

Thank you for your purchase of the Cushcraft XM240. This kit is designed and manufactured to give the best performance and trouble free service. The antenna will perform as specified if the instructions are followed during assembly and installation. If you have technical questions and have access to the World Wide Web you can visit Cushcraft's *TECHEXPRESS* support service (<http://www.cushcraft.com>). The site enables the user to place parts orders, ask technical questions, locate part numbers, initiate warranty inquires and review *Frequently Asked Questions*. Our technical support staff can be reached by phone at (803) 627-7877 (8 AM to 5 PM Eastern time or voice mail after hours), faxed at (803) 627-1764 or can be e-mailed at techsup@cushcraft.com.

WARNING

THIS ANTENNA IS AN ELECTRICAL CONDUCTOR. CONTACT WITH POWER LINES CAN RESULT IN DEATH OR SERIOUS INJURY. DO NOT INSTALL THIS ANTENNA WHERE THERE IS ANY POSSIBILITY OF CONTACT WITH OR HIGH VOLTAGE ARC-OVER FROM POWER CABLES OR SERVICE DROPS TO BUILDINGS. THE ANTENNA, SUPPORTING MAST AND/OR TOWER MUST NOT BE CLOSE TO ANY POWER LINES DURING INSTALLATION, REMOVAL OR IN THE EVENT PART OF THE SYSTEM SHOULD ACCIDENTALLY FALL. FOLLOW THE GUIDELINES FOR ANTENNA INSTALLATION RECOMMENDED BY THE U.S. CONSUMER PRODUCT SAFETY COMMISSION AND LISTED IN THE ENCLOSED PAMPHLETS.

Antenna System Planning

Before assembly, take time to review your installation plans for the antenna. Location of the antenna is very important. Surrounding objects such as trees, power lines, buildings, and other antennas will interact with an HF Yagi. To minimize the effects of surrounding objects, mount the antenna as high and in the clear as possible. Metallic guy wire within 30 feet of this antenna, if broken with strain insulators, will improve performance. **YOU MUST INSURE THAT NEITHER PEOPLE OR PETS CAN COME IN CONTACT WITH YOUR ANTENNA WHILE IT IS IN OPERATION. DEADLY VOLTAGES AND CURRENTS MAY EXIST. ALSO, SINCE THE EFFECTS OF EXPOSURE TO RF ARE NOT FULLY UNDERSTOOD, LONG TERM EXPOSURE TO INTENSE RF FIELDS IS NOT RECOMMENDED. THERE IS A WARNING STICKER WHICH MUST BE ATTACHED TO THE BOOM AS SHOWN IN FIGURE A.** Plan your installation carefully. If you use volunteer helpers be sure that they are qualified to assist you. Make certain that everyone involved understands that you are in charge and that they must follow your instructions. If you have any doubts at all, employ a professional antenna installation company to install your antenna.

System Grounding

Direct grounding of the antenna, mast and tower is very important. This serves as protection from lightning strikes and static buildup. A good electrical connection should be made to one or more ground rods directly at the base of the tower or mast using at least #10 AWG ground wire and non-corrosive hardware. For details and safety standards, consult the National Electrical Code. A coaxial lightning arrester should be used. Cushcraft offers several different models such as the LAC series.

Assembly

The assembly procedure for the XM240 consists of assembling the following subassemblies. 1) Verification of Parts. 2) Boom Assembly. 3) Element Assembly. 4) X-Hat Assembly. 5) Feed System Assembly. 6) Boom-to-Mast Clamp Assembly. 7) Boom Truss Assembly. Assembly of the XM240 will be easiest if the preceding steps are performed in the given order. **Please read through the entire assembly procedure before beginning.**

1-Verification of Parts

Verify all parts are present by using the XM240 Master Parts List. Check off each part when it is counted. There are extra parts intentionally shipped with this antenna. Place common hardware in temporary containers for ease of assembly. Note all hardware is Stainless Steel.

Part No.	Description	Metric Equivalent	Quantity	Qty Check
LCA	40 Meter Loading Coil		4	___
MNXM	Matching Network		1	___
XM240BA	2-1/2" x 59-15/16" Aluminum Tube, 6 holes	6.3 x 152.2 cm	1	___
XM240BB	2-1/2" x 71-15/16" Aluminum Tube, 6 holes	6.3 x 182.7 cm	2	___
XM240BC	2-1/2" x 59-15/16" Aluminum Tube, 10 holes	6.3 x 152.2 cm	1	___
XM240BD	2-3/8" x 12" Aluminum Tube, 8 holes	6.0 x 30.5 cm	2	___
XM240BE	2-3/8" x 12" Aluminum Tube, 4 holes	6.0 x 30.5 cm	1	___
XM240EA	1-3/8" X 84" Aluminum Tube slotted both ends	3.5 x 213.4 cm	1	___
XM240EB	1-1/4" x 48" Aluminum Tube slotted one end	3.2 x 121.9 cm	4	___
XM240EC	1-1/8" x 48" Aluminum Tube slotted one end	2.9 x 121.9 cm	4	___
XM240ED	1" x 32" Aluminum Tube slotted one end	2.5 x 81.3 cm	4	___
XM240EF	1/2" x 48" Aluminum Tube slotted one end	1.3 x 121.9 cm	4	___
XM240EG	3/8" x 36" Aluminum Tube9 x 91.4 cm	2	___

XM240

Part No.	Description	Metric Equivalent	Quantity	Qty Check
XM240EH	1-38" x 42" Aluminum Tube slotted one end, drilled one end	3.5 x 106.7 cm	2	___
XM240EJ	3/8" x 42" Aluminum Tube	.9 x 106.7 cm	2	___
X79FS	6" Feed Strap	15.2 cm	2	___
XHR	34-1/2" x 3/16" Aluminum Rod	.5 x 87.6 cm	8	___
010011	#8-32 Stainless Steel Nut		2	___
010082	1/4-20 x 1" Hex Bolt	0.6 cm - 20 x 2.5 cm	32	___
010084	1/4" Stainless Steel Flat Washer	0.8 cm	60	___
010085	1/4-20 Stainless Steel Nut	0.6 cm	4	___
010207	3/8" Stainless Steel Flat Washer	0.9 cm	6	___
010208	3/8" Stainless Steel Lock Washer	0.9 cm	6	___
010209	3/8" Stainless Steel Nut	0.9 cm	6	___
010719	1/4"-20 x 3" Stainless Steel Hex Bolt	0.6 cm	8	___
010120	8-32 x 2" Stainless Steel Machine Screw	5.1 cm	2	___
010231	8-32 x 1-3/4" Stainless Steel Machine Screw	4.4 cm	8	___
011941	#8 Stainless Steel Lock Washer		4	___
013209	2-7/8" Center-to-center U-Bolt 4" Long	7.3 cm -10.2 cm Long	3	___
014387	#8-32 Stainless Steel Lock Nut		14	___
014399	1/4" Stainless Steel Lock Nut	0.6 cm	60	___
014498	1-3/8" Cush-a-Clamp	3.5 cm	8	___
014588	1/4" x 3-1/2" Stainless Steel Hex Bolt	0.6 x 8.9 cm	4	___
014592	1/4" Stainless Steel Flat Washer 1/8" Thick	0.6 x 0.3 cm	2	___
014597	8-32 x 2-3/4" Stainless Steel Machine Screw	7.0 cm	2	___
024259	1/8" Thimble	0.3 cm	4	___
024624	1/8" Cable clamp	0.3 cm	12	___
024623	5/16" x 4" Turnbuckle	0.8 x 10 cm	2	___
030407	5/8" Worm Clamp	1.6 cm	8	___
030409	11/16" Worm Clamp	1.7 cm	4	___
030411	1-1/8" Worm Clamp	2.9 cm	8	___
030412	1-1/2" Worm Clamp	3.8 cm	8	___
050077	3/8" Black Plastic Cap	0.9 cm	4	___
054526	2-1/2" Black Plastic Cap	6.4 cm	2	___
094622	30' Phillystran cable	.914m	1	___
124567	1" x 8" Drilled Fiberglass Insulator	2.5 x 20.3 cm	1	___
170035	2-1/2" Formed Aluminum Vee Blocks	6.4 cm	3	___
190026	Element Bracket		8	___
190028	Half Washer		8	___
194542	8" x 8" x 1/4" Aluminum Mounting Plate	20.3 x 20.3 x 0.6 cm	1	___
194791	2" x 4" x 1/8" Drilled aluminum truss bracket	5.1 x 10.2 x 0.3 cm	1	___
194707	4" x 24" x 3/16"	10.2 x 61.0 x .5	2	___
290326	Danger Label		1	___
324506	8" x 5-1/4" x 3/16" Drilled Extruded Aluminum Bracket	20.3 x 13.3 x 0.5 cm	2	___
324509	4" x 5-1/4" x 3/16" Drilled Extruded Aluminum Bracket	10.2 x 13.3 x 0.5 cm	4	___

Figure 1A

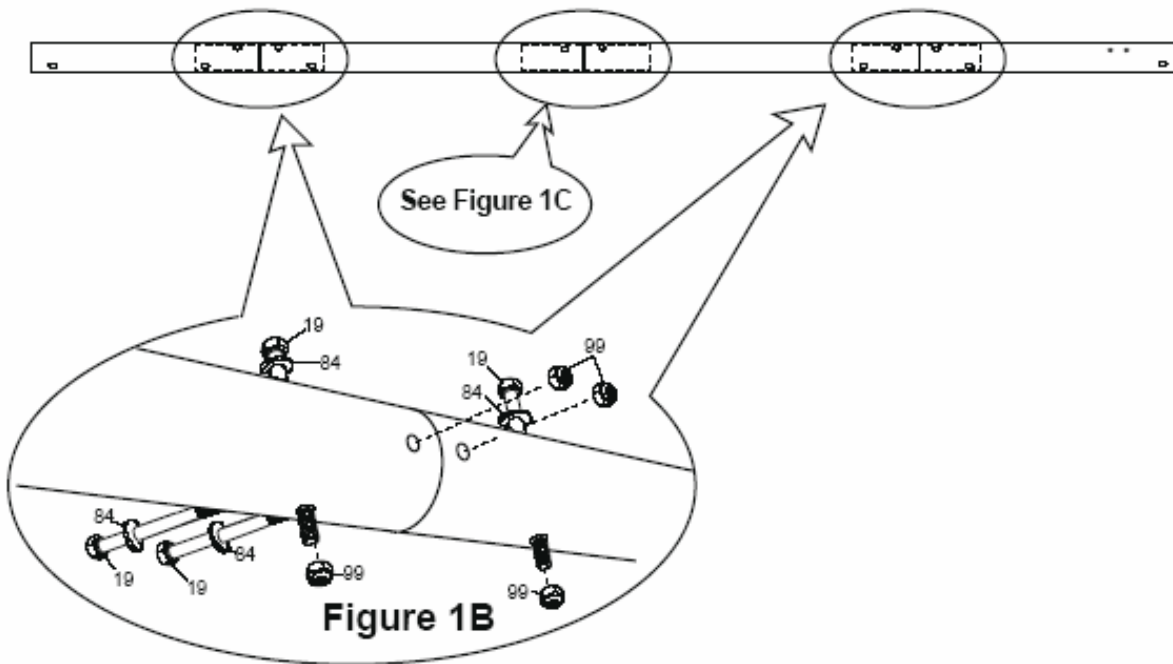
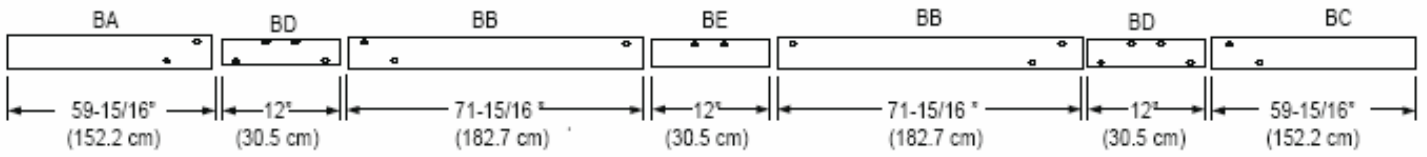

Figure 1B





1-Boom Assembly

Lay out boom sections as shown in Figure 1A. Secure the two outer connections as shown in Figure 1B. The middle connection is made using the mast mounting hardware as shown in Figure 1C.

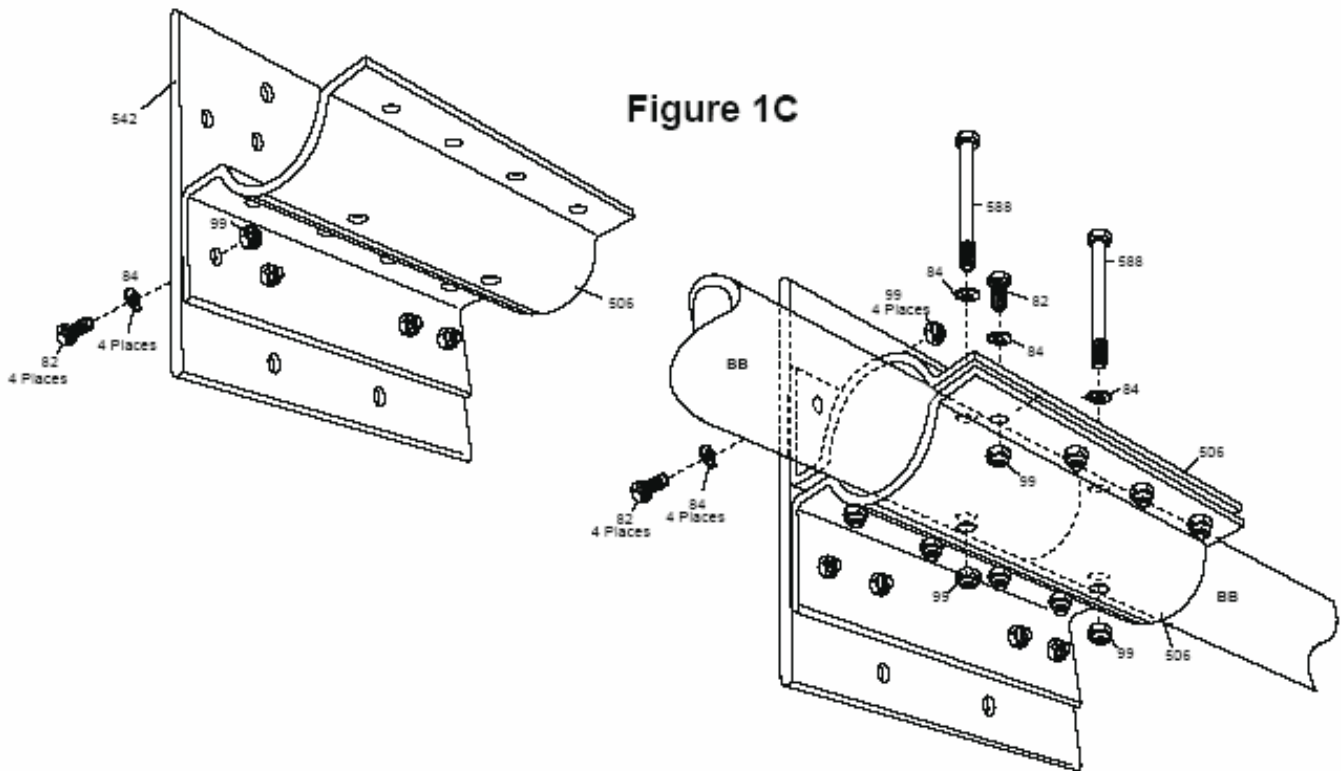
ID	Part #	Description	Dimensions	Qty
BA	XM240BA	Aluminum Tube	2-1/2" x 59-15/16" (6.3 x 152.2 cm)	1
BB	XM240BB	Aluminum Tube	2-1/2" x 71-15/16" (6.3 x 182.7 cm)	2
BC	XM240BC	Aluminum Tube	2-1/2" x 59-15/16" (6.3 x 152.2 cm)	1
BD	XM240BD	Aluminum Tube	2-3/8" x 12" (6.0 x 30.5 cm)	2
BE	XM240BE	Aluminum Tube	2-3/8" x 12" (6.0 x 30.5)	1
19	010719	SS Hex Bolt	1/4-20 x 3" (7.6)	8
84	010084	SS Lock Washer	1/4"	8
99	014399	SS Lock Nut	1/4-20	8

Figure 1C

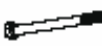

ID	Part #		Description	Dimensions	Qty
82	010082		Hex Bolt	1/4-20 x 1" (2.5 cm)	16
84	010084		SS Lock Washer	1/4" (0.6 cm)	18
99	014399		SS Lock Nut	1/4" (.6 cm)	18
506	324506		Aluminum Bracket	8" x 5-1/4" x 3/16" (20.3 x 13.3 x .5 cm)	2
542	194542		Alu Mounting Plate	8" x 8" x 1/4" 20.3 x 20.3 x .6 cm)	1
588	014588		SS Hex Bolt	1/4" x 3-1/2" (.6 x 8.9 cm)	2

2 - Element Assembly

Figure 2A and 2B show the steps required for element assembly. Identify the parts required using the Element Subassembly Parts List. Slide EH sections over fiberglass insulator (567) until #8 screw holes line up (Figure 2B). Insert screws (120) through holes and secure with lock washer (941) and nut (11).

Assemble elements referring to Figure 2A. Pay close attention to all dimensions shown. Use Chart A to determine your final element half length adjustments.

Chart A
Element Half Lengths



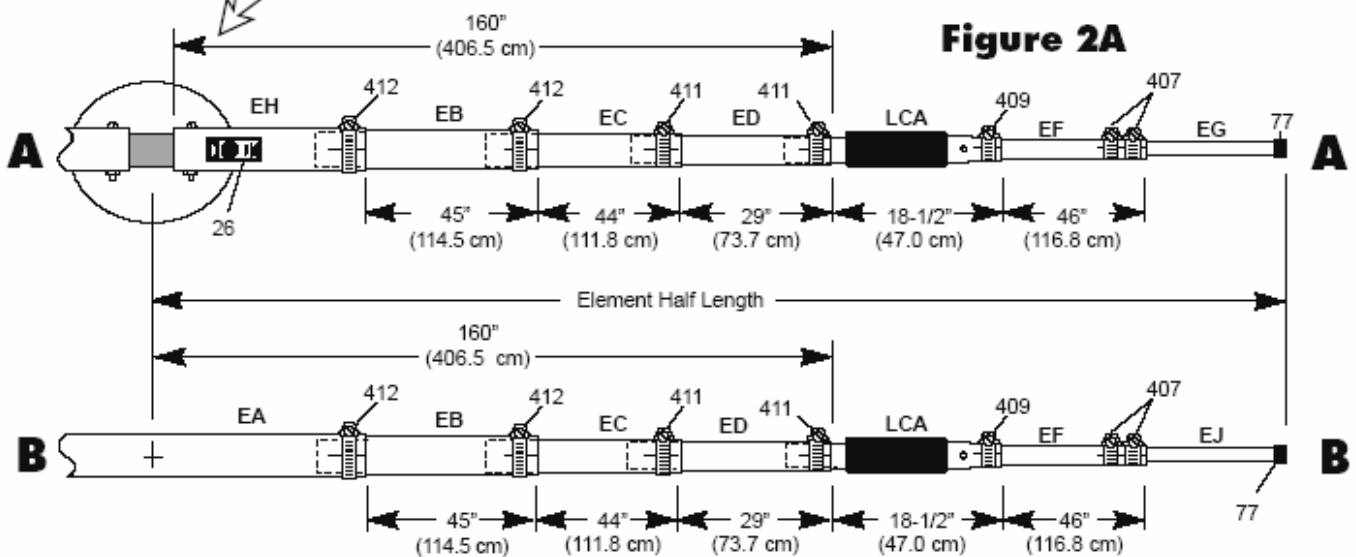
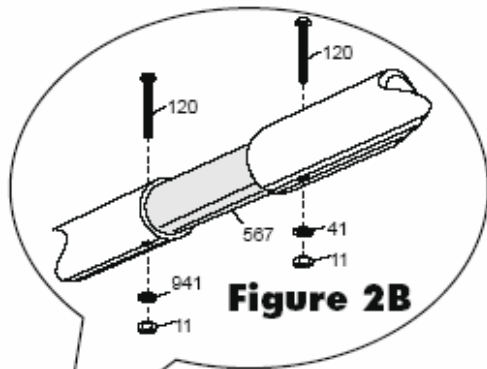

	A	B
CW	252.5"	262.5"
7.025 MHz	(641.3 cm)	(666.7 cm)
MID	249.5	258.5
7.125 MHz	(633.7 cm)	(656.6 cm)
PH	246.5	255.5
7.225 MHz	(626.1 cm)	(649.0 cm)

ID	Part #	Description	Dimensions	Qty
11	010011	SS Nut	#8-32	2
26	290326	Warning Sticker		1
41	011041	SS Lock Washer	#8	2
77	050077	Black Plastic Cap	3/8" (0.9 cm)	4
120	010120	SS Machine Screw	#8-32 x 2" (5.1 cm)	2
407	030407	Worm Clamp	5/8" (1.6 cm)	8
409	030409	Worm Clamp	1 1/16" (1.7 cm)	4
411	030411	Worm Clamp	1-1/8" (2.9 cm)	8
412	030412	Worm Clamp	1-1/2" (3.8 cm)	8
567	124567	Fiberglass Insulator	1" x 8" (2.5 x 20.3)	1
EA	XM240EA	Aluminum Tube	1-3/8" x 84" (3.5 x 213.4 cm)	1
EB	XM340EB	Aluminum Tube	1-1/4" x 48" (3.2 x 121.9 cm)	4
EC	XM240EC	Aluminum Tube	1-1/8" x 48" (2.9 x 121.9 cm)	4
ED	XM240ED	Aluminum Tube	1" x 32" (2.5 x 81.3 cm)	4
EF	XM240EF	Aluminum Tube	1/2" x 48" (1.3 x 121.9 cm)	4
EG	XM240EG	Aluminum Tube	3/8" x 36" (.95 x 91.4 cm)	2
EH	XM240EH	Aluminum Tube	1-3/8" x 42" (3.5 x 106.7 cm)	2
EJ	XM240EJ	Aluminum Tube	3/8" x 42" (.95 x 106.7 cm)	2
LCA	LCA	Loading Coil		4



3 - X-Hat Assembly

Figure 3A shows the steps for assembly of the four X-Hats. Identify the parts required using the X-Hat Subassembly Parts List. Two XHR rods attach to each 40 meter coil (LCA). The rods may be mounted in any position relative to the element or boom.

ID	Part #		Description	Dimensions	Qty
31	010231		SS Machine Screw	#8-32 x 1-3/4" (4.4 cm)	4
87	014387		SS Lock Nut	#8-32	4
28	190028		Aluminum Bracket		4
28	190028		Aluminum Half Washer		4
XHR			Aluminum Rod	3/8" x 34-1/2" (1.0 x 87.8 cm)	4

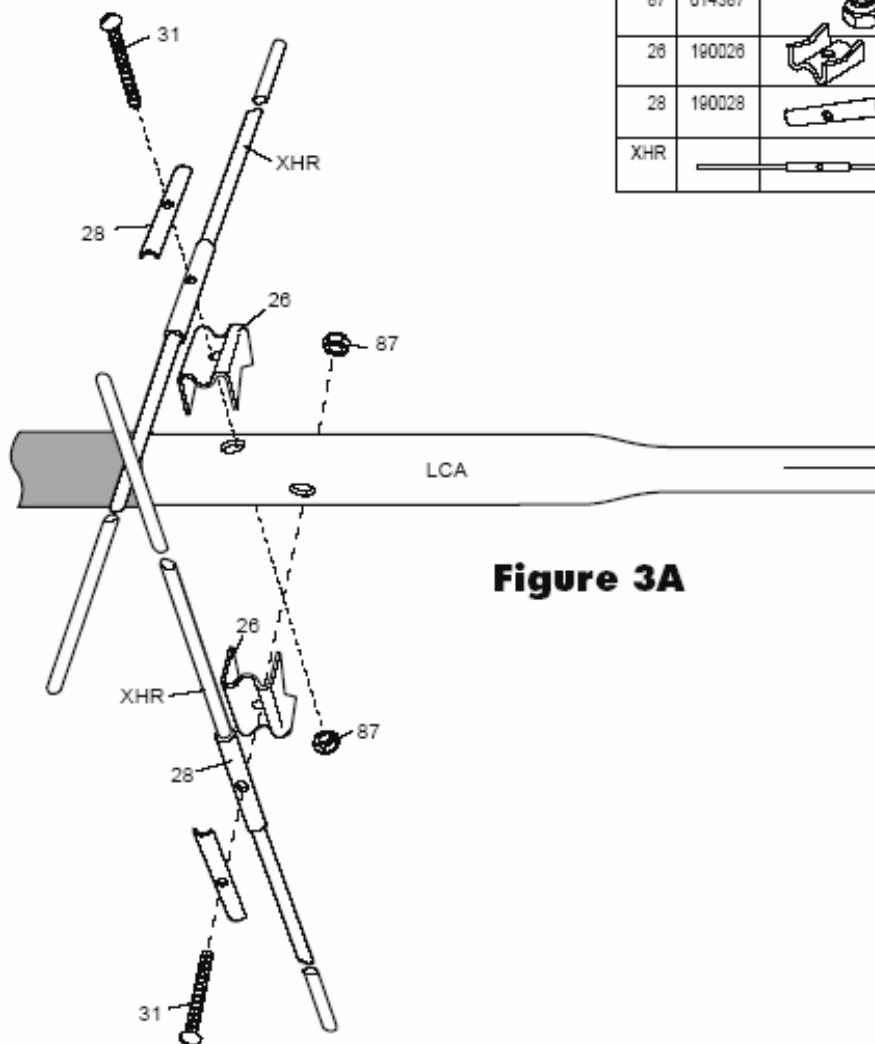

Figure 3A

4 - Element to Boom Assembly

Figure 4A, 4B and 4C show the steps for element mounting on the XM240 boom. Identify the parts required using the Element to Boom Subassembly Parts List. Attach the two brackets (509) to the boom using the hardware shown. The end of the truss assembly is shown in Figure 4A but is not to be assembled at this time. Attach the U-Channel Plate (793). Attach elements using 4 Cush-a-Clamps (98) (Figure 5A). The element pictured in Figure 5A is the Driven Element. Both elements mount with the same hardware.

Figure 4A**Figure 4B****Figure 4C**

Figure 5A



ID	Part #		Description	Dimensions	Qty
41	011941		SS Lock Washer	#8	4
82	010082		SS Hex Bolt	1/4-20 x 1" (.6 x 2.5 cm)	7
84	010084		SS Lock Washer	1/4" (.6 cm)	22
85	010085		SS Nut	1/4-20 (.6 cm)	2
87	014387		SS Lock Nut	#8-32	4
97	014597		SS Machine Screw	8-32 x 2-3/4 (7.0 cm)	2
98	014498		Cush-a Clamp	1-3/8" (3.5 cm)	6
99	014399		SS Lock Nut	1/4" (.6 cm)	22
212	010212		SS Hex Bolt	1/4-20 x 2" (5.1 cm)	2
509	324509		Aluminum Bracket	4" x 5-1/4 x 3/16" (10.2 x 13.3 x .5 cm)	2
588	014588		SS Hex Bolt	1/4" x 3-1/2" (.6 x 10.2 cm)	1
592	014592		SS Flat Washer	1/4" (1/8" thick) (.6 x .3 cm)	2
707	194707		U-Channel Bracket	4" x 24" (10.2 x 61 cm)	1
MN	MNXM		Matching Network		1
FS	X79FS		Copper Braid	1/2" x 6" (1.2 x 15 cm)	2

5 - Feed System Assembly

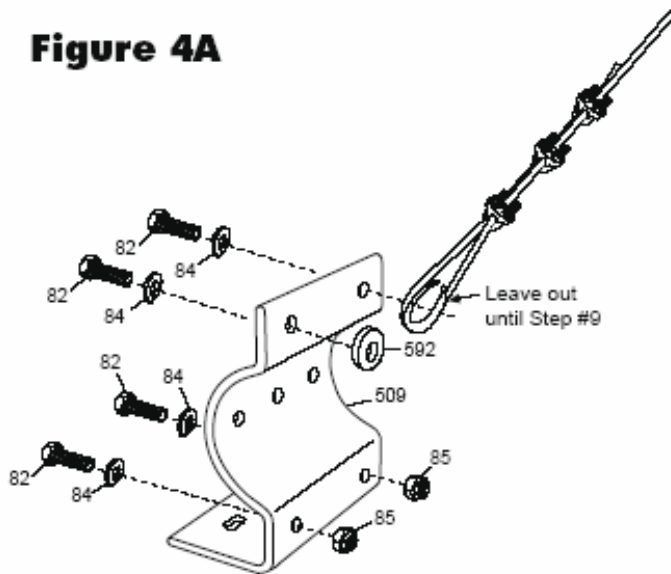
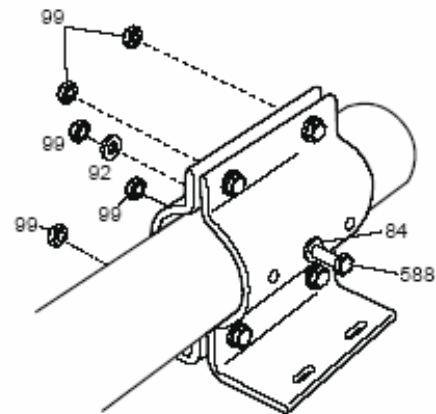
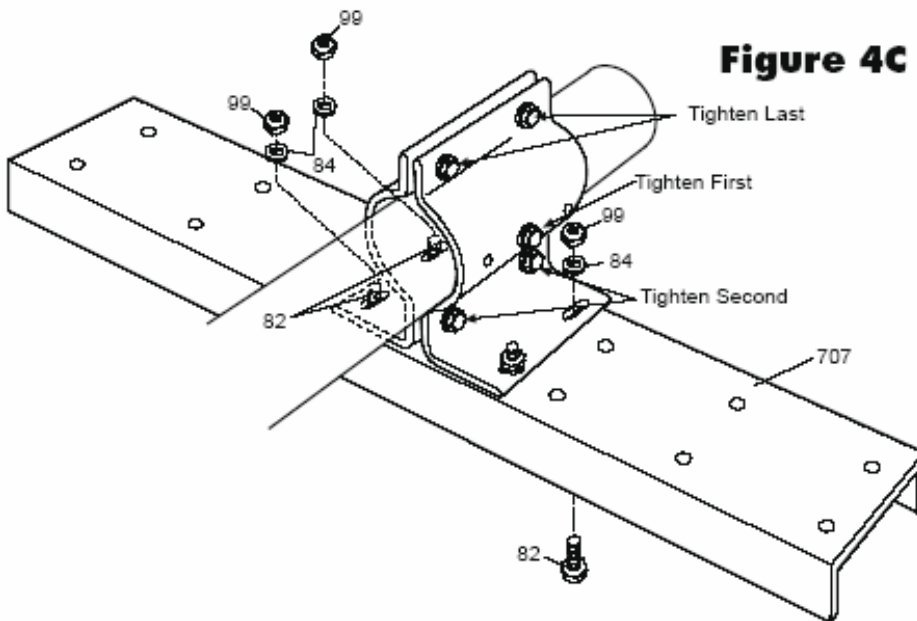
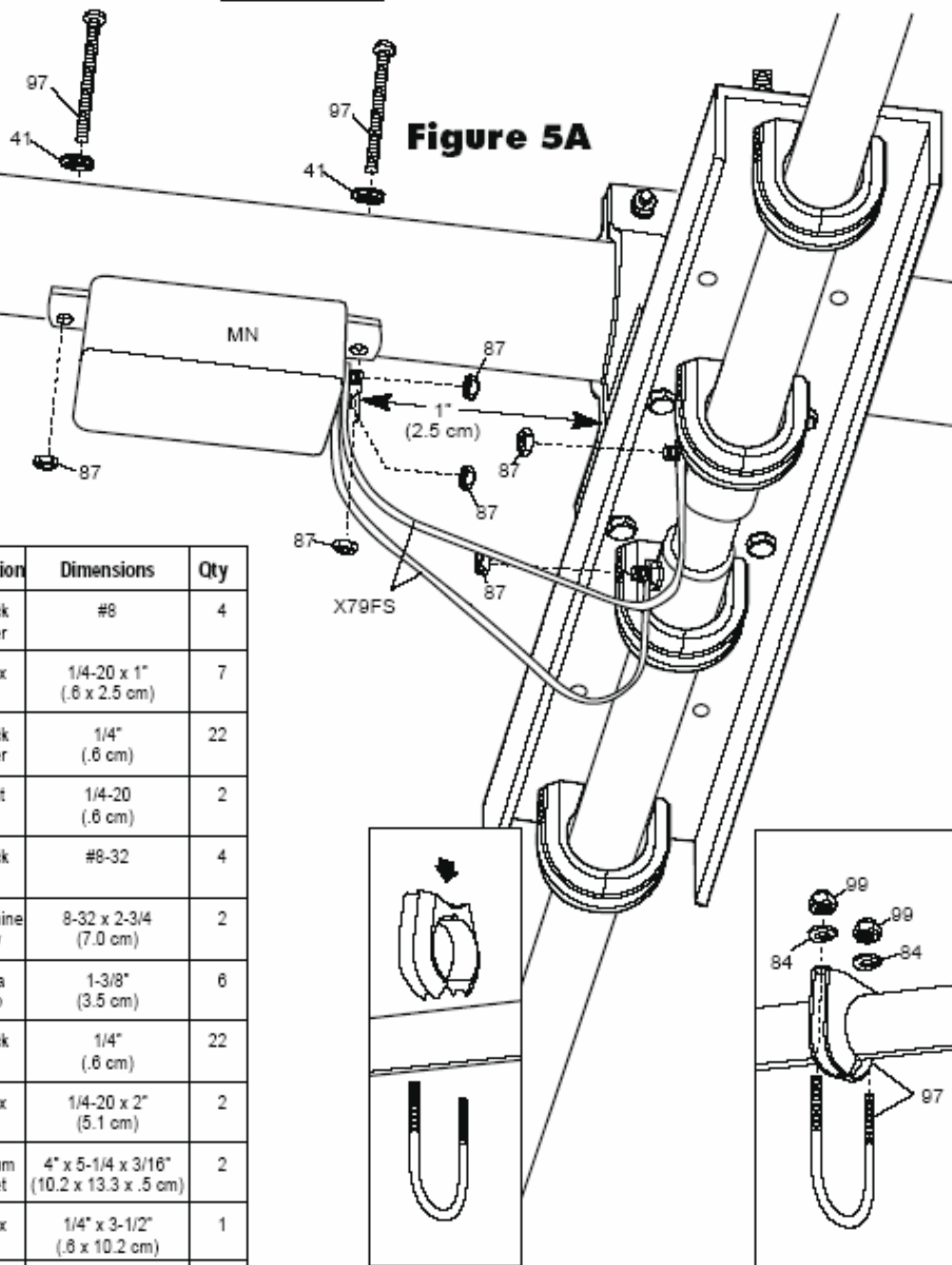
Figure 5A shows the steps for feed system assembly. Identify the parts required using the Feed System Subassembly Parts List. Attach the Matching Network (MN) to the boom as shown above. Attach the Feed Straps (FS) to the two screws on the MN and the two driven element screws with the hardware shown. Position the Feed Straps away from the U-Channel bracket (707).

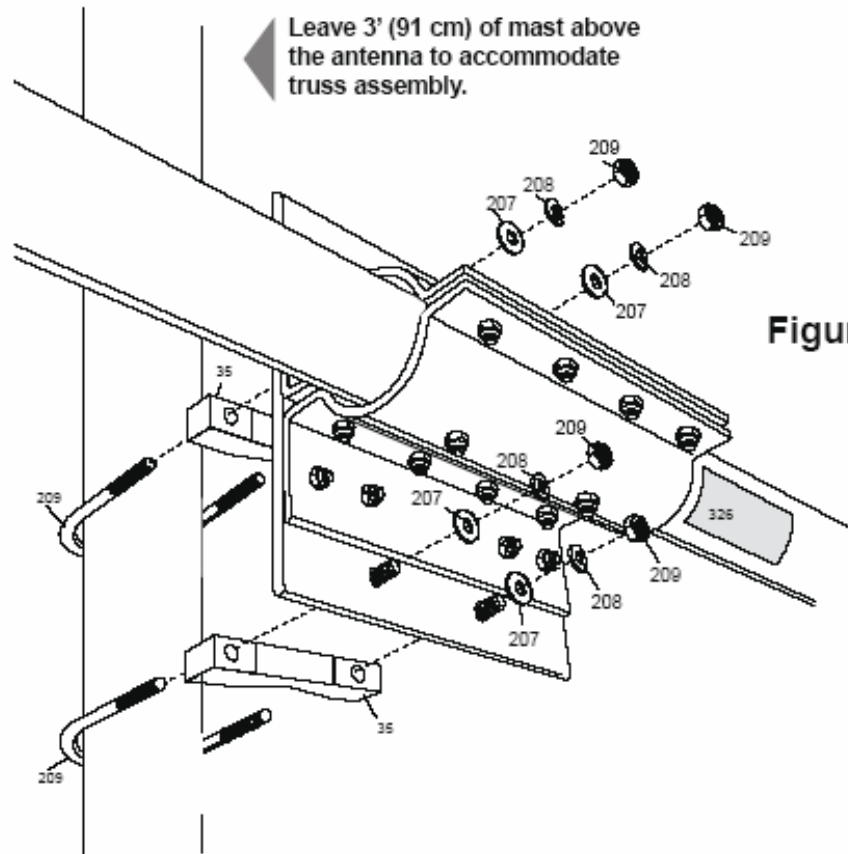







Figure 6A

6-Boom to Mast Clamp Assembly

The antenna is now ready to be mounted to the mast. Attach the antenna mast clamp assembly to the tower mast as shown in Figure 6A. Secure the U-bolts with the hardware shown.

Attach good quality coax with a PL-259 connector to the MNXM matching network. Form a drip-loop with the coax and secure the coax to the boom. Insure PL-259 connector is waterproofed with a good quality sealant after it is attached to the matching network.

ID	Part #		Description	Dimensions	Qty
35	170035		Aluminum V-Block	2-1/2" (6.3 cm)	2
207	010207		SS Flat Washer	3/8" (.95 cm)	4
208	010208		SS Lock Washer	3/8" (.95 cm)	4
209	010209		SS Nut	3/8" (.95 cm)	4
326	290326		Danger Label		1
209	013209		U-Bolt	2-7/8" (7.3 cm)	2

7 - Boom Truss Assembly

Figure 9 illustrates the boom truss assembly. Refer to the boom truss assembly parts list for the hardware required. The XM240 uses Phillystran® cable to guy the boom. The cable is one continuous piece from one boom end to the other. Note the Phillystran cable safety loop that goes around the mast truss bracket.

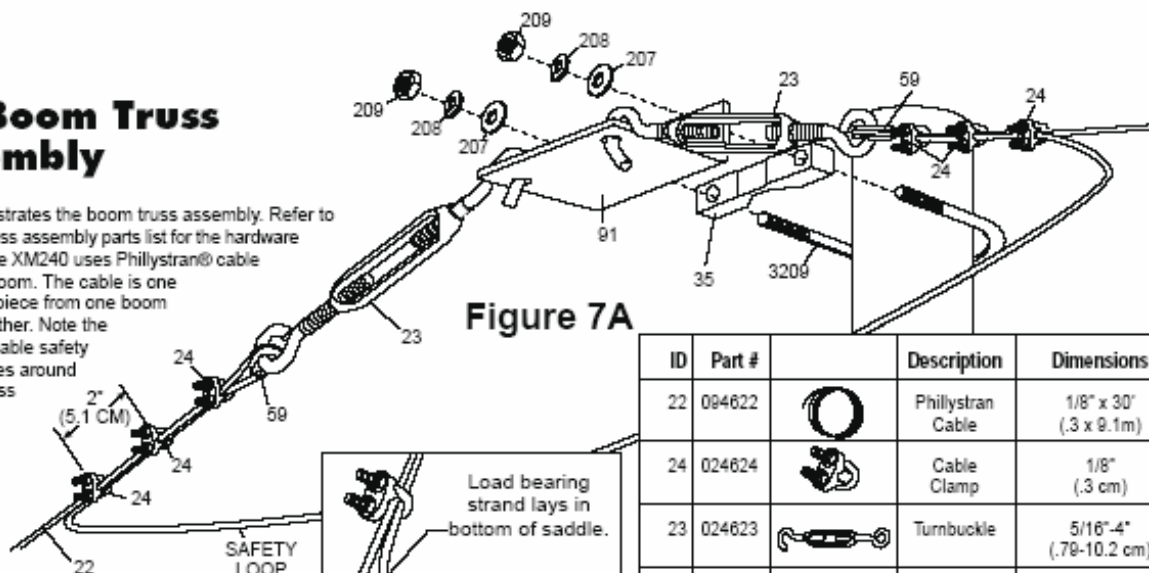

Figure 7A

Attach the truss bracket (91) to the mast 3 feet (1m) above the boom to mast clamp using the 3/8" hardware provided. Position the truss bracket on the same side of the mast as the boom to mast clamp. Unscrew the turnbuckle ends until there is 1/2" (1.2 cm) of thread remaining. Place the jaw of each turnbuckle (23) into the holes of the truss bracket. Place a thimble (59) on the eye of each turnbuckle. Place three loose cable clamps (24) onto the cable end. Reference Figure 9 and place the cable clamp saddle over the load bearing cable. The load bearing cable is the cable that attaches to the boom end. Feed the cable through a turnbuckle eye. Run the cable back through the cable clamps. Place three additional cable clamps on the end of the cable. Feed the cable through the other turnbuckle eye. Run the cable back through the cable clamps. Feed enough cable through these parts until the center of the Phillystran cable coil is located at the truss bracket. Insure there is enough slack in the cable to form a loose safety loop between the turnbuckles. Tighten the cable clamps beginning with the clamp closest to the thimble.

ID	Part #	Description	Dimensions	Qty
22	094622	Phillystran Cable	1/8" x 30' (.3 x 9.1m)	1
24	024624	Cable Clamp	1/8" (.3 cm)	12
23	024623	Turnbuckle	5/16"-4" (.79-10.2 cm)	2
91	194791	Truss Bracket	2" x 42" x 1/8" (5.1 x 10.2 x .3 cm)	1
35	170035	Aluminum V-Block	2-1/2" (6.3 cm)	1
59	024259	Thimble	1/8" (.3 cm)	4
207	010207	SS Flat Washer	3/8" (.95 cm)	2
208	010208	SS Lock Washer	3/8" (.95 cm)	2
209	010209	SS Nut	3/8" (.95 cm)	2
3209	013209	U-Bolt	2-7/8" (7.3 cm)	1

Refer to Figure 4B for attachment of the cable to the boom ends. Place a thimble (59) on the 1/4-20 x 1" bolt. Place three loose cable clamps (24) onto the cable end. Feed the cable end through the element bracket and around the thimble. Run the cable back through the cable clamps. Tighten the cable to remove the majority of the sag from the boom. Space the cable clamps 2 inches (5.1 cm) apart. Insure the load bearing cable is seated in the cable clamp saddle as shown above. Tighten the cable clamps beginning with the clamp closest to the thimble. Cut off excess cable 2" (5.1 cm) after the third cable clamp.

Adjust each turnbuckle to bring each boom end level with the center. Phillystran cable has a minimal amount of stretch over time. A safety wire can be placed through the turnbuckle openings to keep the turnbuckles from unscrewing.

Tuning Procedure

The XM240 may be tuned for operation in the 40 meter band according to Chart A in Section 2. Adjust element EJ on the reflector and element EG on the radiator to set the desired half length referred to in Chart A.

SPECIFICATIONS

Frequency Coverage (Meters)	40	Boom Length, ft (m)	22 (6.7)
Total number of Elements	2	Boom Diameter, in (cm)	2-1/2 (6.35)
Free Space Gain (dBi)	6	Maximum Mast Diameter OD, in (cm)	2-1/2 (6.35)
Maximum Front to Back Ratio (dB)	28	Maximum Wind Survival, mph (kph)	90 (145)
VSWR Minimum	1.1:1	Maximum Wind Surface Area, ft ² (m ²)	5.5 (.51)
VSWR 1.5:1 Bandwidth (KHz)	150	Maximum Power Handling (KW)	2
2:1 Bandwidth (KHz)	250	Weight, lb. (kg)	55 (25)
Longest Element, ft (m)	43.75 (13.3)	Design Safety Factor	1.25
Turning Radius, ft (m)	24 (7.3)		



48 Perimeter Road, Manchester NH 03103 USA • Telephone: 603-627-7877 • Fax: 603-627-1764 • E-mail: sales@cushcraft.com
Web Site: <http://www.cushcraft.com> • International - Tel: +1-603-627-7877 • Fax: +1-603-627-1764

Limited Warranty

Cushcraft Corporation, 48 Perimeter Road, Manchester, New Hampshire 03103, warrants to the original consumer purchaser for one year from date of purchase that each Cushcraft antenna is free of defects in material or workmanship. If, in the judgement of Cushcraft, any such antenna is defective, then Cushcraft will, at its option, repair or replace the antenna at its expense within thirty days of the date the antenna is returned (at purchaser's expense) to Cushcraft or one of its authorized representatives. This warranty is in lieu of all other expressed warranties. Any implied warranty is limited in duration to one year. Cushcraft Corporation shall not be liable for any incidental or consequential damages which may result from a defect. Some states do not allow a limitation on how long an implied warranty lasts or exclusions or limitations of incidental or consequential damages, so the above limitation and exclusion may not apply to you. This warranty gives you specific legal rights, and you may also have other rights which vary from state to state. This warranty does not extend to any products which have been subject to misuse, neglect, accident or improper installation. Any repairs or alterations outside of the Cushcraft factory will nullify this warranty.

XM-240^{1/2}

Este material foi extraído da Internet em **Novembro de 2006**, como forma de auxiliar os amigos ou a construírem a sua própria XM-240, ou a modificarem uma existente.

Esta antena direcional foi a “eleita” a ser utilizada no **WRTC-2006**, que foi realizado como é do conhecimento geral, no **Estado de Santa Catarina**. Foram confeccionadas **52 (cinquenta e duas)** pelo **PP5UA (Pedro)**, de **Florianópolis (SC)**, especialmente para as mesmas **52** estações do WRTC-2006, “espalhadas” pelo litoral do Estado, onde muitos “concurseiros mundiais” tiveram a oportunidade de a testar e utilizar, na prática !

Estas modificações foram efetuadas por **VE6WZ**, do **Canadá**, observe que a preocupação com o indutor (“bobina”), foi o ponto crítico da modificação. Observamos que estas modificações não foram efetuadas nas antenas de PP5UA, são um trabalho nosso, independente, notadamente na tradução do material coligido.

Em um papo informal, com nosso amigo **PP5JD (Jaime)**, em 40m/SSB, ficamos cientes de sua intenção de construir uma 2el para 80m. Isto posto, tratamos de pesquisar a fundo na Internet algo semelhante, e o resultado está aqui. “Dois coelhos numa só”, pois é para 40m e para 80m. O site original, foi para o PP5JD (Jaime) e nestas alturas, ele já deve ter “algo pronto” e “funcionando” (pois “é o estilo dele” ... hi)

De modo a não deixar esta informação tão restrita, decidimos colocar a público não sómente o Manual da XM-240, tanto quanto anexando vários detalhes já traduzidos do site (em inglês). Provendo então, aqueles que desejarem no Brasil ou modificar a sua existente antena (adquirida do PP5UA), ou construir uma, a partir do zero, com subsídios suficientes. Se a construção for muito difícil, entre em contato com PP5UA (Pedro) e solicite uma pronta. Todas estas modificações serão por sua conta e risco. O Pedro não tem nada com isto ! (hi) – e “ele me mata se souber”... (hi)

A nossa mais pura intenção é mesmo “provocar” vocês, que “sonham” com uma antena decente para 80m e 40m, fora da tradicional “dipolinho-da-vida”, porém não tem nenhum material em língua pátria para se guiar. Esperamos sinceramente, que muitos passem a construir uma destas (ou as duas) e “botem pra quebrar” nos concursos mundiais, projetando nosso Brasil, no lugar que merece: no “**Top-Five**” !

Como última informação (“conselho se preferir...”):

Estas modificações devem ser efetuadas por alguém que realmente saiba o que está fazendo, pois são extremamente sensíveis ! Se efetuadas incorretamente podem afetar sobremaneira o rendimento das antenas ! O termo “sabe o que está fazendo” denota conhecer a fundo a Teoria de Antenas, não apenas “acho que sei”, notadamente nestas “coisas” encurtadas... que são terríveis de ajustar ! (hi)

Ahhhh ! Esta antena tem quase **7 m** de gôndola, com **12m** de Elemento Maior.

Mesmo assim ela não é pequena ! Pense muito bem, como a vai construir !!!!

(Hummmm... Acopladores de Antena, servem para “enganar seu rádio”, mais nada...)

O texto completo (em inglês), está em:

<http://www.qsl.net/ve6wz/index.html> (último acesso em **Novembro 2006**)

Boa Sorte de **PP5VX (Bone)** em **GG53qs**

XM-240^{1/2}

O INDUTOR (“Bobina”) ORIGINAL



XM-240 Original de VE6WZ

Aspecto do Indutor sem a capa de proteção

(O valor “637” indicado é a Reatância Total – X, em Ohms !)

Dados do Indutor Original:

68 (sessenta e oito) espiras

Fio AWG¹ #12 (2.03 mm ou 3 mm²) – é utilizado cerca de **4,08m** de fio...

Diâmetro: $\frac{3}{4}$ ” (19mm)

Vide **Ítem 567** no Manual, indicando um diâmetro de 1”: isto não é correto... (!!!)

Comprimento: Cerca de **5.43” (138 mm)**, de um total de 8” (Ítem 567 no Manual)

Indutância Calculada²: **15.113 (quinze) µh**

Lê-se “quinze microhenrys e cento e treze décimos”

Perdas Ôhmicas Calculadas³: **8 (oito) Ω** – lê-se “oito ohms”

Fator de Mérito (Q): **81 (oitenta e um)** – o “Q” é adimensional...

BW (Largura de Banda): **84 khz**

Frequência de Ressonância: **6.713,20 khz** ou **6,71320 Mhz** (Cuidado com as unidades !)

¹ A “**Tabela AWG**” de Fios não é mais utilizada. Está obsoleta. O padrão atual mundial é o **mm²**

² Foi utilizado um Analizador de Antenas da MFJ, o modelo MFJ-259B.

Os limites de Reatância Total (X), estão entre no mínimo de **7Ω** e no máximo de **650Ω**

Observe os valores apresentados no display...

³ Para calcular as perdas ôhmicas do indutor, foi utilizado um programa chamado **COIL V1.30** de autoria de **K6STI (Brian)**, que está disponível na Internet (Nota: para o **MS-DOS** ...)

XM-240^{1/2}

O NOVO INDUTOR (“Bobina”)



XM-240 Original de VE6WZ

Aspecto do Novo Indutor sem o verniz de proteção e suportes.
(O valor “607” indicado é a Reatância Total – X, em Ohms !)

Dados do Novo Indutor:

11.5 (onze e meia) espiras

Tubo de Alumínio de 3/16” (4.7mm)

Diâmetro: **5” (127 mm)**

Comprimento: **5” (127 mm)**

Indutância Calculada⁴: **14.403 (quatorze) µh**

Lê-se “quatorze microhenrys e quatrocentos e três décimos”

Perdas Ôhmicas Calculadas⁵: **0.859 Ω**

Lê-se “oitocentos e cinquenta e nove décimos de ohm” ... menos de **1 Ω (um ohm) !**

Compare com as Perdas Ôhmicas da original (**8 Ω**): **931% menos perdas !!!**

Fator de Mérito (Q): **767 (setecentos e sessenta e sete)** – o “Q” é adimensional...

Compare com o Q da original (**81**): **946% mais alto !!!**

BW (Largura de Banda): **10 khz**

Sim ! Aumentando o Q, aumenta a eficiência da antena, porém a BW se reduz... é um compromisso !

As relações entre o Q, BW e a eficiência de uma antena, devem ser perfeitamente conhecidos !

Frequência de Ressonância: **6.708,80 khz** ou **6,70880 Mhz** (Cuidado com as unidades !)

⁴ Foi utilizado um Analizador de Antenas da MFJ, o modelo **MFJ-259B**.

Os limites de Reatância Total (X), estão entre no mínimo de **7Ω** e no máximo de **650Ω**

Observe os valores apresentados no display...

⁵ Para calcular as perdas ôhmicas do indutor, foi utilizado um programa chamado **COIL V1.30** de autoria de **K6STI (Brian)**, que está disponível na Internet (Nota: para o **MS-DOS** ...)

XM-240^{1/2}

O NOVO INDUTOR (“Bobina”)



XM-240 Original de VE6WZ
Aspecto do Novo Indutor com o verniz de proteção e suportes.

O verniz de proteção tem cor vermelha (como na foto)

Observe as “travas de nylon” (na cor preta) para “acomodar as espiras no lugar”

Epa.... e as considerações de peso⁶ deste novo indutor ?

O peso do indutor original (bruto, com fio de cobre) é cerca de **354,5 g**

Por utilizar tubo de alumínio, o peso do novo conjunto (bruto, sem os suportes de reforço: veja a foto acima) é algo próximo de **376,3 g** !

Uma diferença de apenas 6 % (seis por cento) a mais !!!

Logo, o peso do novo conjunto não é então, um problema !

Atenção ! O tubo de alumínio é utilizado sómente na Antena de 40m !

⁶ O original indica o peso em “onças” (“onces”, abreviado “oz”), como no Brasil (e na maior parte do mundo) é adotado o SI, que utiliza a (sub)unidade de peso “grama” (de kg), convertemos na razão de que **1 onça vale 31,01g** - e os valores apresentados ficam mais “tangíveis” do que onças, tigras ou tatus... (hi)

XM-240½



As duas antenas (80m e 40m) na torre telescópica no QTH de **VE6WZ**
(observe que está na altura mínima, quase rente ao telhado...hi)

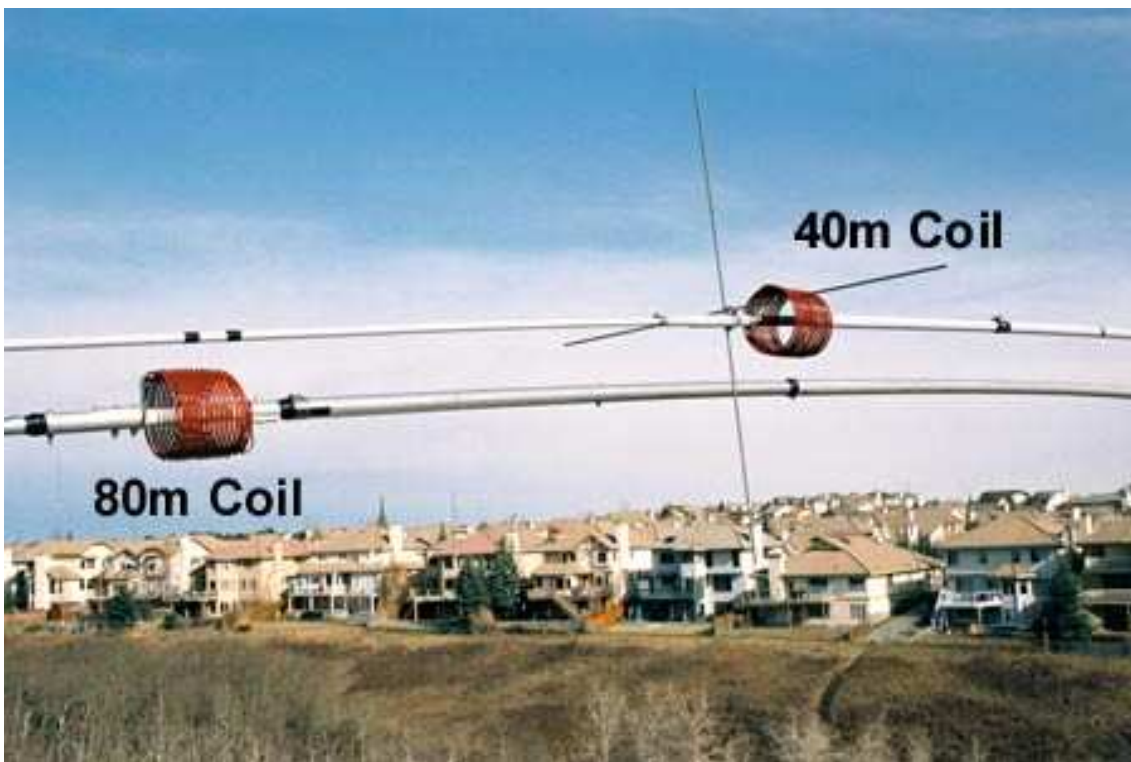

O aspecto dos novos indutores (“Coil”) das duas antenas (80m e 40m)
(observe que ainda está na altura mínima, quase rente ao telhado...hi)

XM-240½



As vantagens da torre telescópica de **30 (trinta) metros**, no QTH de **VE6WZ**
(observe que agora está na altura máxima...)

A antena logo abaixo, parece uma **TH6DXX (HyGain)** de **6el (20m/15m/10m)**
(não há nenhuma indicação no texto original, isto é “*guess-work*” nosso ... hi)

Para quem conhece o “tamanho” de uma TH6DXX, observe por comparação !!!!

Nota: Para os “CVA-maníacos”, e “would-be contest killers” – observe que não é a quantidade de potência que faz a diferença. Mas sim, a antena na qual você irá colocar o seu “todo poderoso” linear ! De nada adianta linear em ... dipolos da vida ! A antena é mais importante que o linear, pois “You can’t work them, if you can’t hear them”... (hi)
As antenas dipolo são historicamente “surdas” em concursos !

Imagine então, operar no CVA, nesta altura, e com estas antenas em 80m/40m ... (hi)

XM-240½



Aspecto dos Indutores prontos para a montagem...

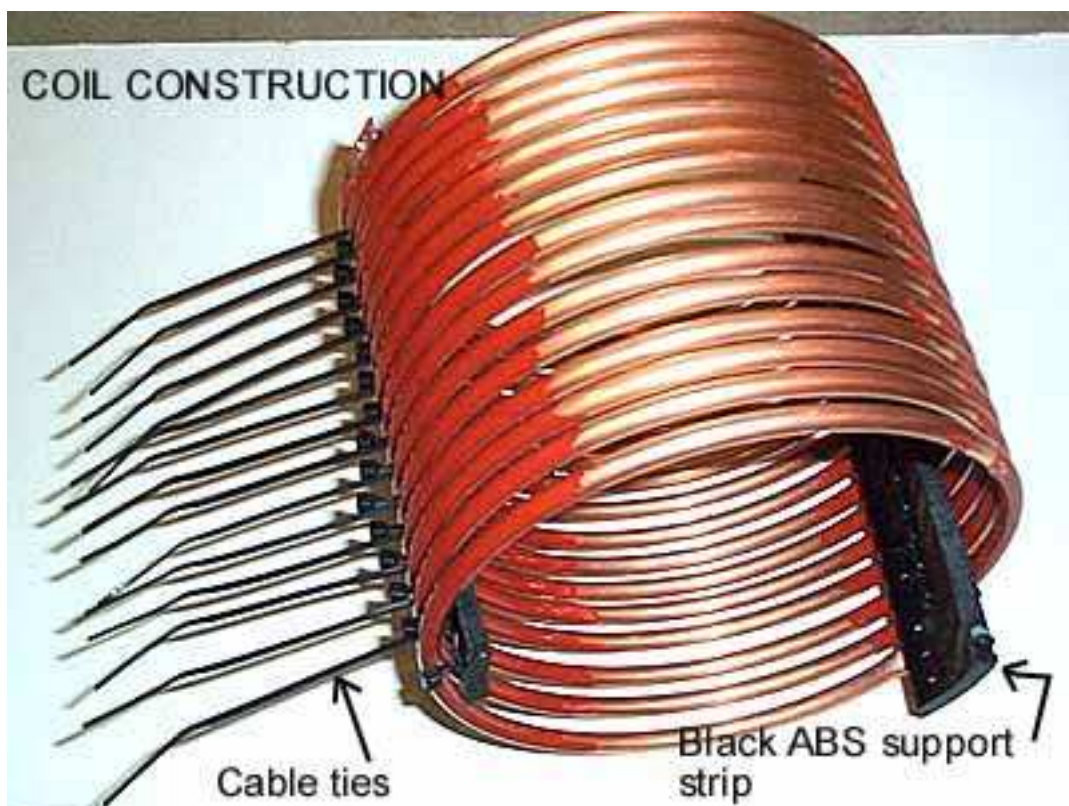

A Construção dos Indutores ([da Antena de 80m ...](#))
O Suporte de ABS e as “travas de nylon” (“cable ties”) sem cortar os excessos...
Observe o verniz parcial, sómente na posição das “travas de nylon”

XM-240½



Detalhes das “travas de nylon” que suportam as espiras do indutor...
... está parcialmente “envernizado”...
... e os excessos das “travas”, já foram cortados ...
(observe que este indutor de 80m, é confeccionado com tubos de cobre)



... e algo que não temos no Brasil: **Neve !**
(isto “bagunça” completamente tanto o Q, quanto os parâmetros do Indutor...)